

Gas
Transmission

Gas Quality Blending Services Webinar

13th October 2020

We will start at 09.32 to
allow people to finish
previous meetings

nationalgrid



Slido.com
#23019

Welcome – Ian Radley (Head of Gas System Operations)

- Gas Quality blending consultation has been driven by customer and stakeholder feedback
- Overview of the consultation themes and process
- Please ask questions and engage with us – Your feedback is critical



Who we are...



**Phil
Hobbins**

Commercial Codes
Change Manager



**Rachel
Hinsley**

Senior Codes
Change Lead



**Jenny
Pemberton**

Stakeholder
Engagement Manager

Logistics



Should last for approximately 60 – 90 min



Questions and polling via slido #23019



All callers will be placed on mute



We will circulate the slides and a recording of this webinar

Agenda

Gas Quality Blending Project

Consultation Themes

1. Proposed service concept
2. Applicable terminals
3. Operational impacts and safety
4. Regulatory changes
5. Charging / offering the service

Question and Answer

Background

- Some of our upstream **stakeholders** have expressed interest in National Grid **developing gas quality blending** services at National Transmission System (NTS) **entry points**
- **Supplies of gas into the NTS are reduced** when they are unable to provide on-spec gas, leading to **loss of revenue** and **lower production** for these stakeholders
- We are currently **exploring** the potential for an **interruptible blending service** under which we would agree to **accept non-compliant gas** from an upstream party(s), provided that **sufficient blend gas** was being delivered from other operators at that location
- Such a service could help **maximise the recovery of UK Continental Shelf (UKCS)** gas to the benefit of GB security of supply and apply downward pressure on GB wholesale gas prices
- Declining offshore production, changing supply dynamics and new sources of gas **may lead to more requests for blending services in future**

Our project has three workstreams...

Technical feasibility studies

- **Phase 1:** build and test terminal models
- **Phase 2:** modelling study using forecast flows and gas qualities
- Network Innovation Allowance (NIA) study currently in flight

Safety Assurance

- How do we mitigate any risk of transporting off-spec gas?
- What additional controls could be implemented?
- Gas Safety (Management) Regulation (GS(M)R) Safety Case amended

Commercial & regulatory changes

- Supporting the development of the business rules
 - How the service would be offered
 - Charging structure
 - Regulatory framework and any Licence or Uniform Network Code (UNC) changes required

Our work has reached a stage where we would like to **consult** with you, our customers and stakeholders, and **seek views** on some of our ideas and key principles. The key principles include a range of **operational**, **commercial** and **regulatory** topics

Current Arrangements

Gas Safety (Management) Regulations

- Regulation 8 of GS(M)R covers the **content** and **characteristics** of gas
- GS(M)R requires UK gas transporters to prepare a **Safety Case** which must be accepted by the **Health and Safety Executive (HSE)**

Gas Quality Management

- We **constantly monitor** the content and characteristics of gas at each individual NTS sub-terminal and blending point
- When gas is recorded as being **non-compliant** we **curtail** the **flow** of the non-compliant supply source

Proposed Service Concept

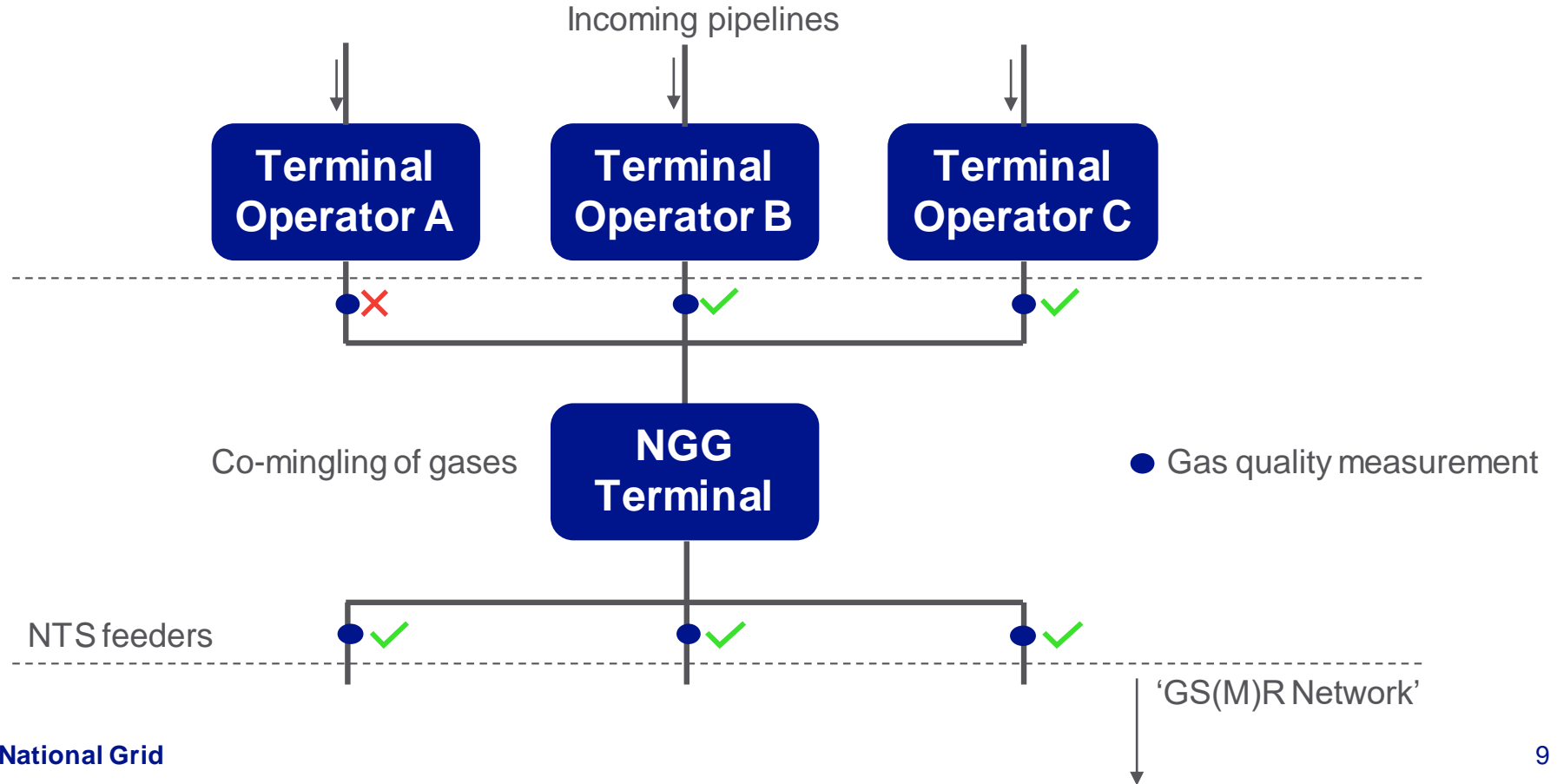

Context (1): GS(M)R Review

The Institution of Gas Engineers & Managers (IGEM) recently published a consultation document which proposed to **amend the UK gas quality specification** and to transfer it out of GS(M)R into an IGEM standard. The following steps are anticipated within this process:

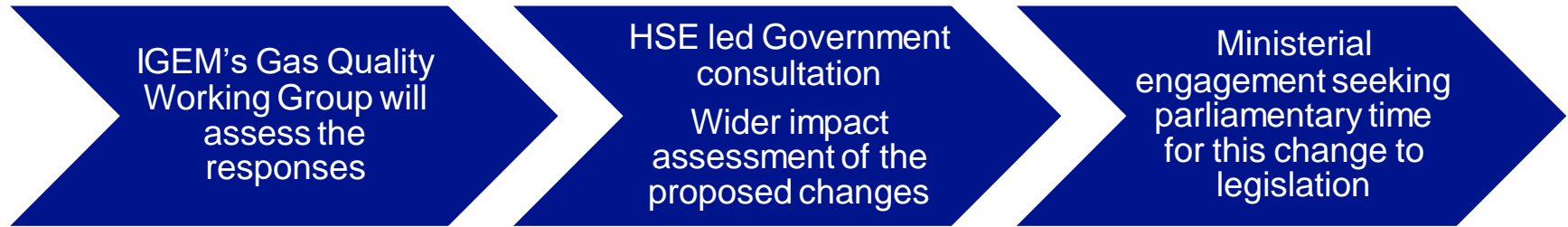

According to our current estimate of timescales, **we do not expect** that any **wider spec gas** will be **delivered onto the NTS before 2023** given all the changes required, including contractual amendments

The GS(M)R review **may resolve some of the current challenges** that our upstream stakeholders are facing however a **blending service might still have value**

Context (2): How does this fit with our RIIO-2 submission?

- Gas quality blending services **do not feature** in our RIIO-2 submission
- This is because the project is in an **exploratory phase**

We have asked for funding to **re-design our Bacton terminal**

- Ofgem has indicated they **support our proposal**
- **Gas quality blending services** are included within this re-design work

Current Contractual Relationships at NTS Entry Points

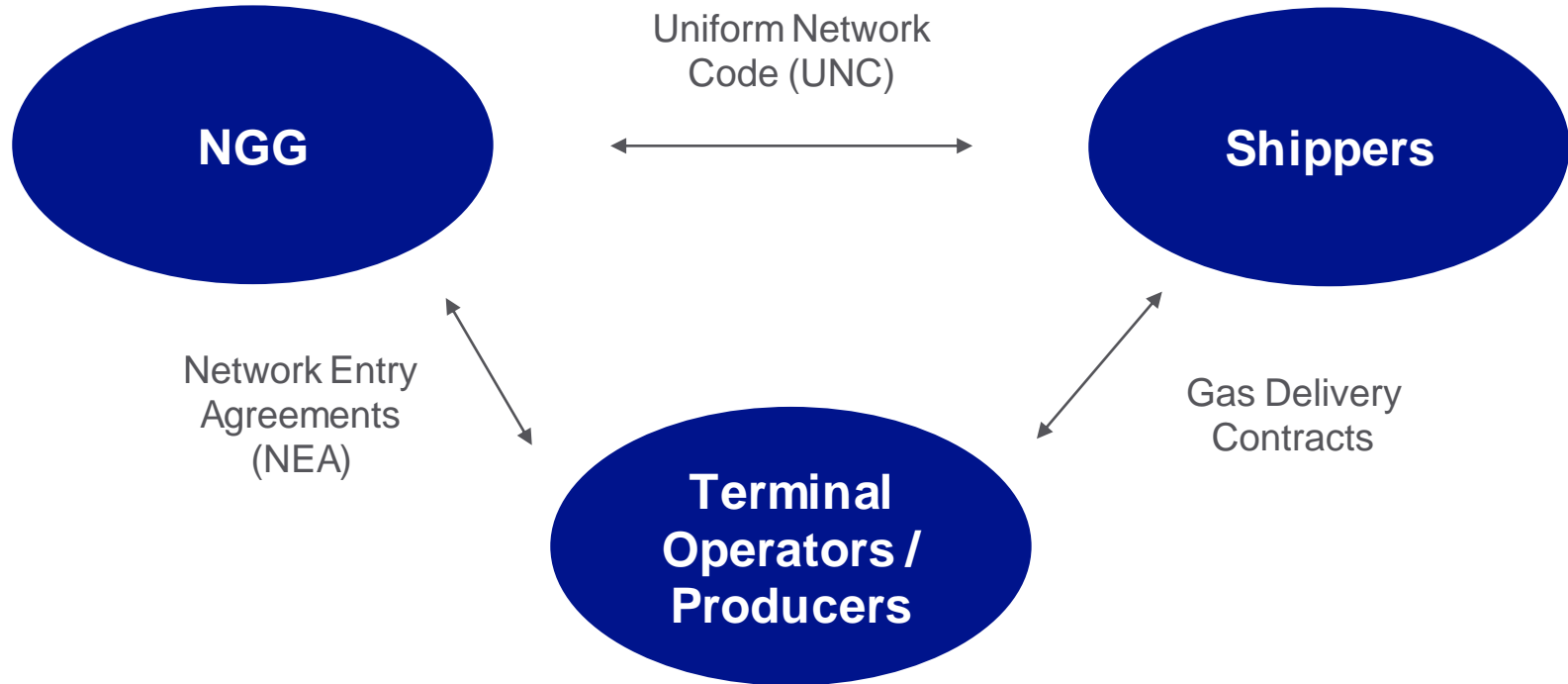

Blending Points

- ‘Blending points’ are designated in our Safety Case as being **points or areas of pipework that are close to the upstream terminal**
- There are **no domestic gas offtake points** between the blending point and the terminal
- At locations where multiple parties deliver gas, the blending point is the NGG terminal. **Fortuitous co-mingling** may occur to bring any off-spec gas into compliance by the time it enters the GS(M)R network, i.e. the NTS pipelines that leave the National Grid terminal
- **Bacton and St. Fergus** are good examples of this type of entry point

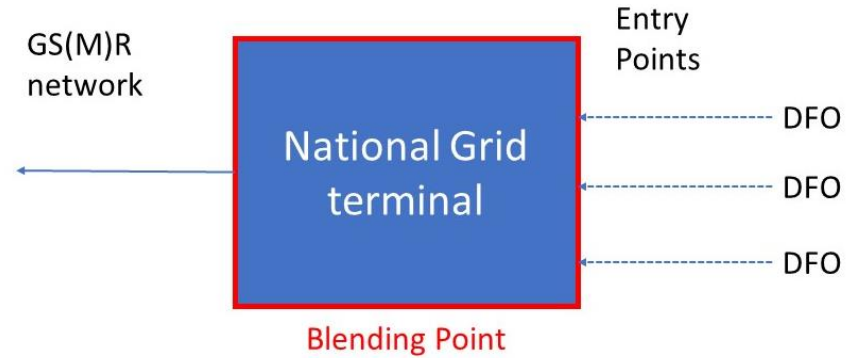

Blending Point at an NTS entry location with multiple DFOs

Consultation Themes

Theme 1:
Proposed
service concept

Theme 2:
Applicable
terminals

Theme 3:
Operational
impacts and
safety controls

Theme 4:
Regulatory
change

Theme 5:
Charging /
offering the
service

Theme 1: Do you support us exploring this service in principle?

The service concept:

Blending non-GS(M)R compliant gas within NGG terminals to achieve a compliant blend ahead of the 'GS(M)R Network'

Do you support us developing such a service?

What risks do you think there might be?

What parameters would you be interested in a blending service applying to e.g. Wobbe Index?

Theme 2: Applicable Terminals

To offer a gas quality blending service, multiple supplies of gas must be present at an NTS entry point

A compliant blend will need to be achieved prior to gas entering the 'GS(M)R Network'

We think that terminals could be categorised as follows:

1. Terminals most suitable to offer gas quality blending services
2. Terminals potentially suitable to offer gas quality blending services
3. Terminals where a gas quality blending is not currently feasible

Theme 2: Bacton

- Multiple sources of gas
- Our terminal serves as a 'blending point'

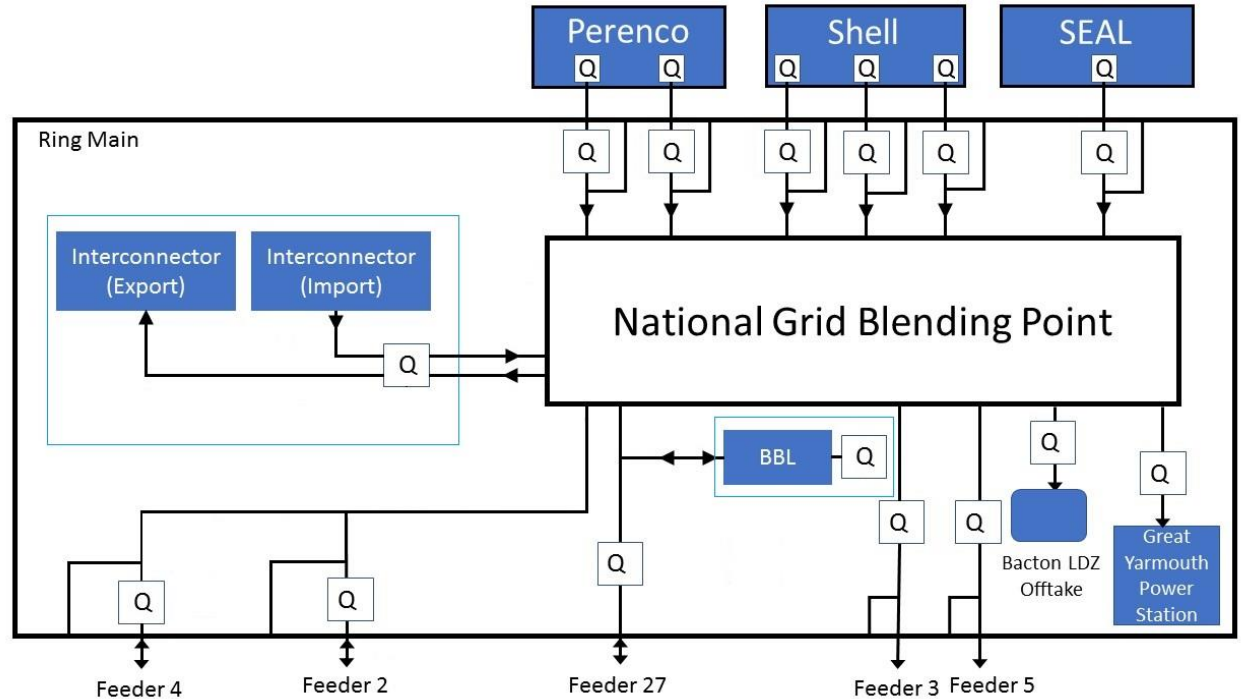

Note: This is an updated diagram from that which appears in the consultation document

Theme 2: St Fergus

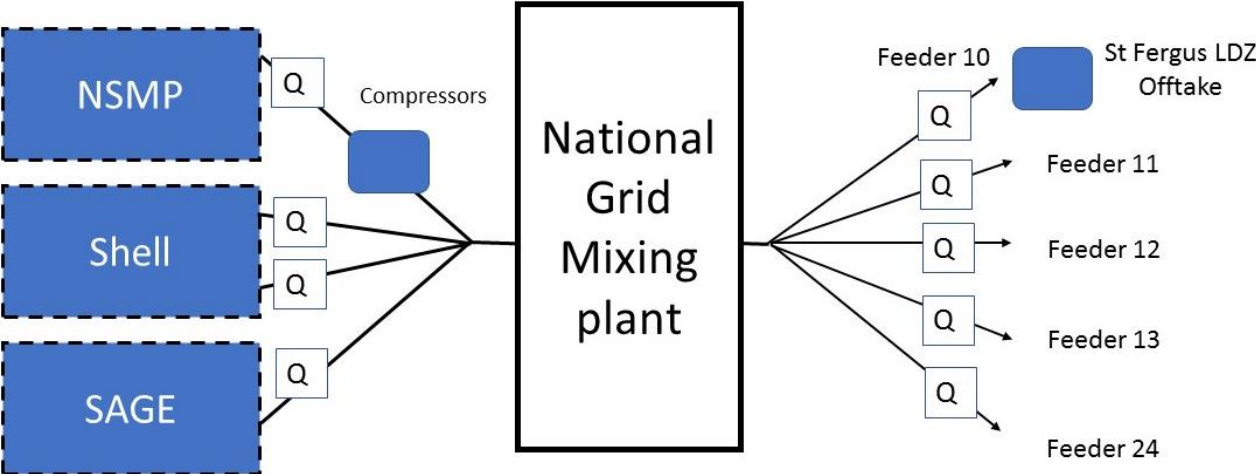

- Multiple sources of gas
- Our terminal serves as a 'blending point'

Theme 2: Applicable terminals

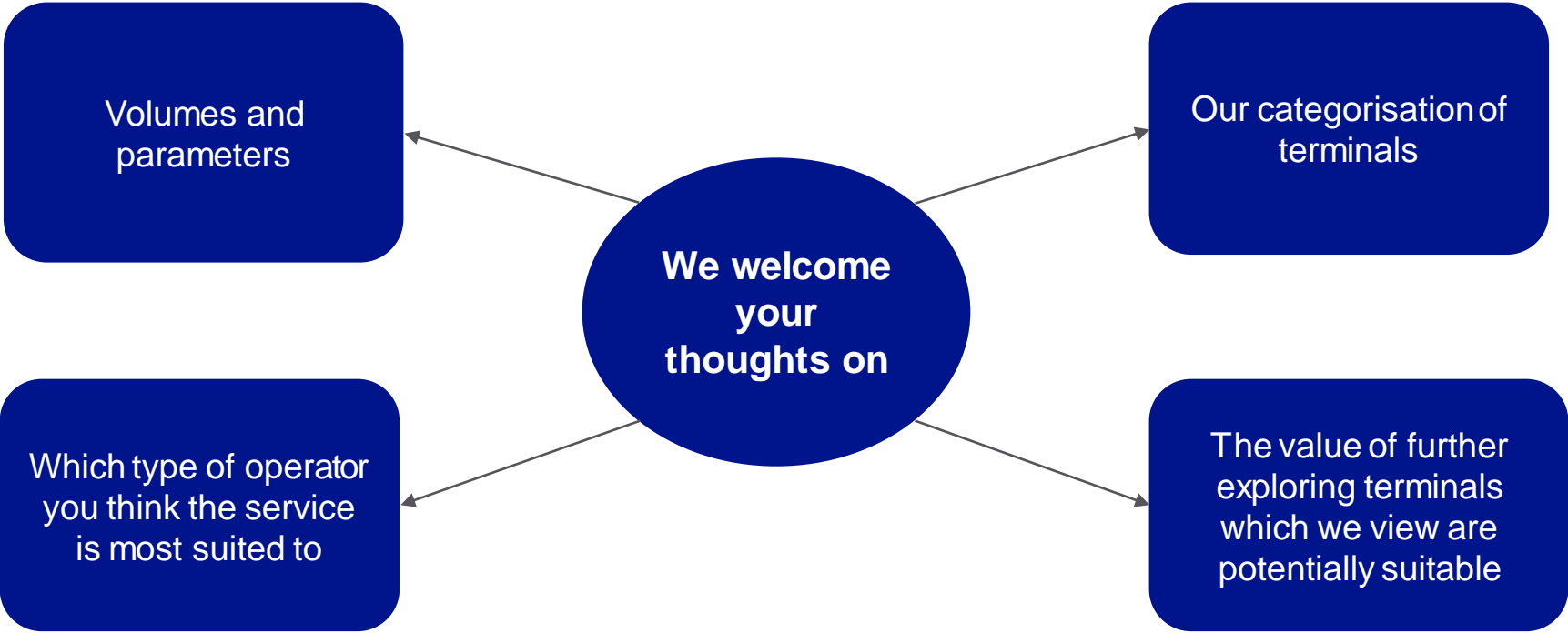

Theme 3: Operational impacts and safety controls

UNC Modification 0714, *Amendment to Network Entry Provision at Perenco, Bacton Terminal*- was raised in February 2020. This is an '**enabling**' modification to temporarily amend the **Wobbe Index** within the Network Entry Provisions between Perenco and NGG at Bacton, from 47.2MJ/M³ to 46.5MJ/M³.

<https://www.gasgovernance.co.uk/0714>

Our work on this proposal has and is **providing learning** for the wider gas quality blending project.

Theme 3: Potential Safety Controls

Pre set
minimum flow
and quality
requirements

Operational
tolerances

Interruptible
service

Alarm
strategy

Additional gas
quality monitoring
equipment

Enhanced
communication

Accountabilities
roles and
responsibilities

Theme 4: Regulatory change



Theme 4: Which regulatory mechanism should we use?

Consent

- An 'extension' of our GT Licence
- Granted by Ofgem with conditions attached
- Timebound
- Sets out how costs and revenues are recorded

De-minimis

- Services that do not require consent from Ofgem
- Total of all de-minimis activities is less than 2.5%

Excluded Services

- Detailed in Special Condition 11 of Licence
- Revenues included in annual reporting

Licensed activity

- Gas Quality Blending could be a new Licence activity
- Consultation
- Open and transparent

Theme 4: Additional changes

UNC Changes?

UNC TPD I includes Special Delivery Arrangements

- Is this suitable?
- What other changes are required?

NEA Changes?

Current contract between a terminal operator and NGG is the NEA

- Is this suitable for gas quality blending?
- Is a separate contract required?

Theme 5: Charges

Should this service be chargeable?

Who should be charged?

How should we charge?

How long should the duration of the service be?

Should those providing blend gas receive a benefit share?

Theme 5: Offering the service

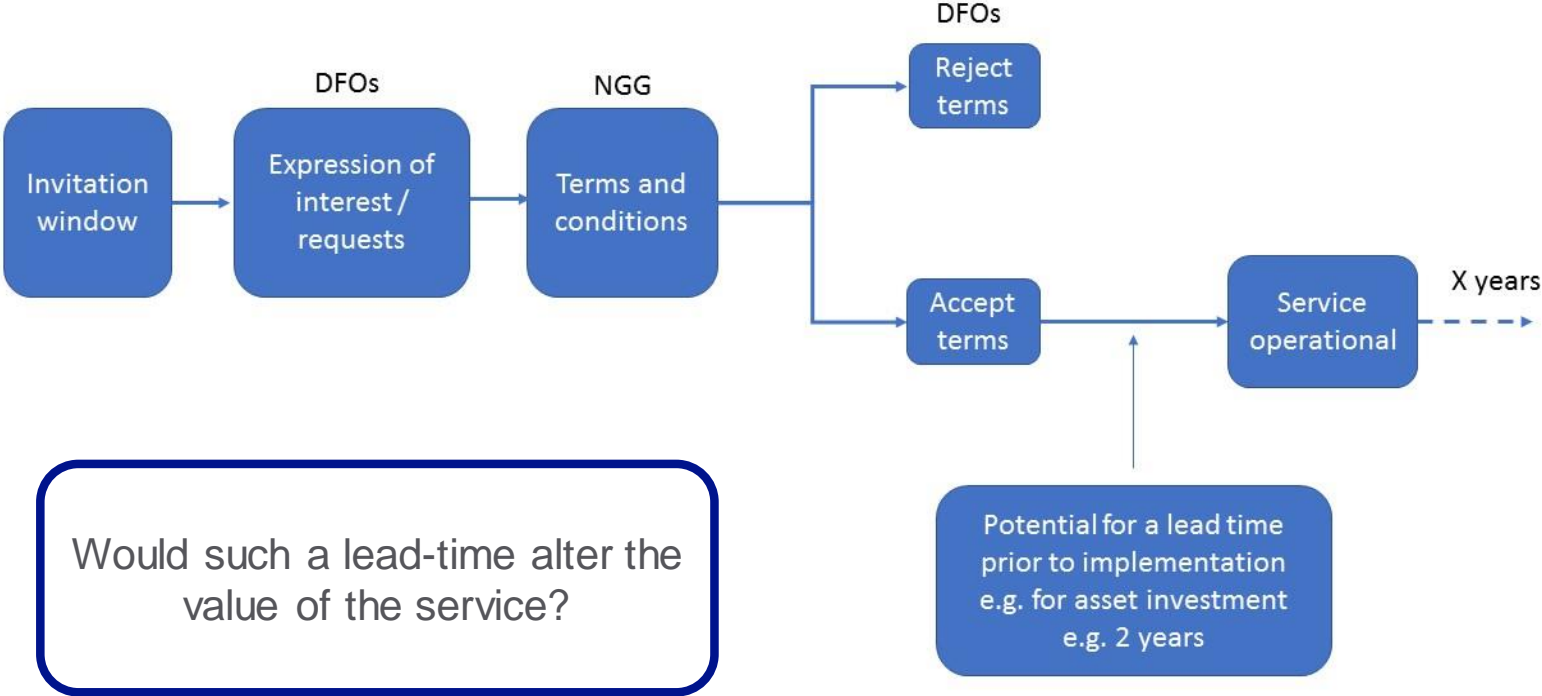

Theme 5: Risks

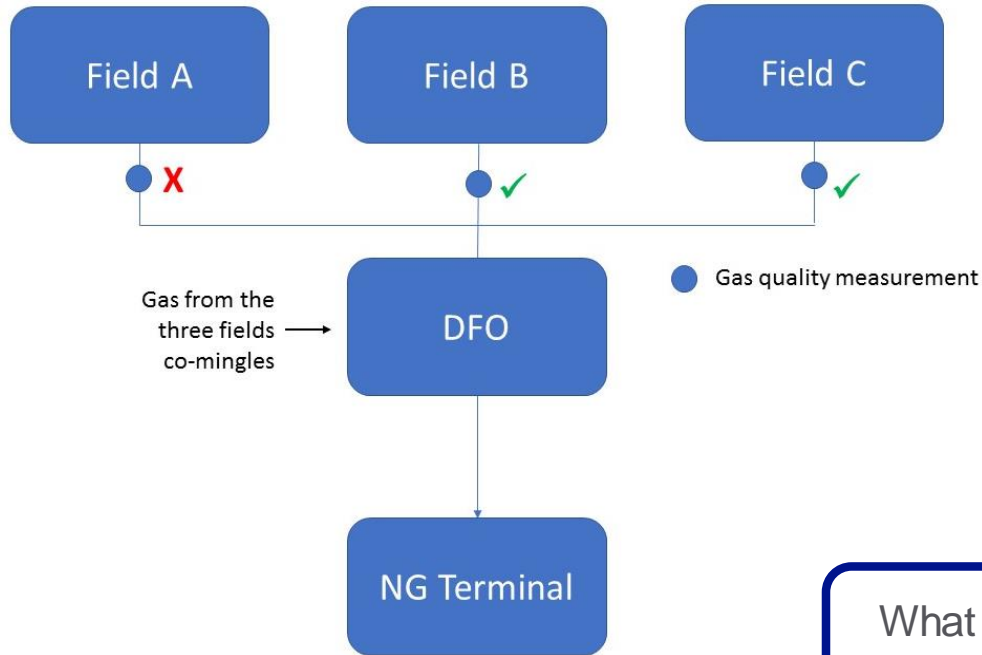

The service would be offered on an **interruptible** basis.

If the field B or field C had an unplanned outage field A may need to be curtailed.

What would this mean for the gas flow and the upstream terminal?

Next steps

- Consultation opened on 17th September for a 2 month period, **closes on Friday 13th November 2020**
- We are willing to host bi-lateral conversations for anybody who would like them. Please contact:
 - Phil Hobbins on 07966 865623 or by email philip.hobbins@nationalgrid.com or
 - Rachel Hinsley on 07811 762440 or by email rachel.hinsley1@nationalgrid.com
- Consultation report to be collated and issued in December 2020

Quick poll

**Have we explained the consultation clearly
(including the consultation document)?**

Please give a reason for your answer

Quick poll

Would you like a 1-1 with us to discuss your views?

If yes, please include your name in your response

Q & A



Phil Hobbins
Commercial Codes
Change Manager



Rachel Hinsley
Senior Codes
Change Lead



Thank you



national**grid**